

# NEW ERA SLG

系列三相无刷同步发电机  
SERIES THREE-PHASE BRUSHLESS  
SYNCHRONOUS ALTERNATOR

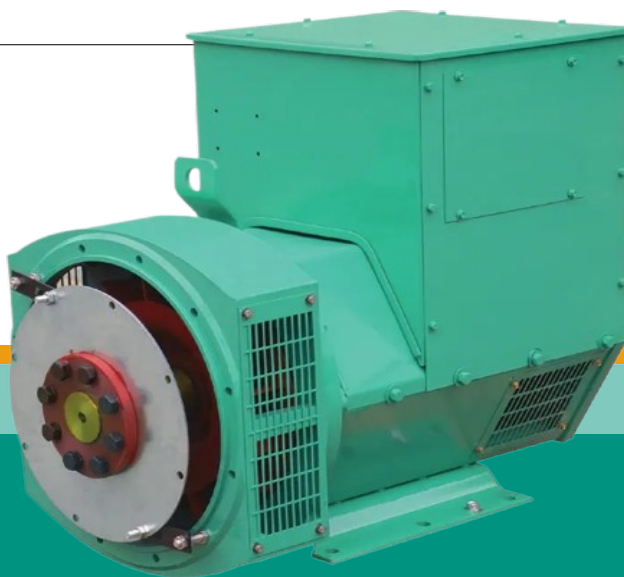

## SLG224 TECHNICAL DATA SHEET

### 50Hz CLASS "H"

RATINGS	绕组形式 311 / 功率因数0.8 Winding 311 / 0.8 Power Factor												绕组形式05 Winding 05					
	持续/125k/40°C Cont./125K/40°C						持续/125k/40°C Cont./125K/40°C						持续/125k/40°C Cont./125K/40°C					
定额/温升/环温T° Duty / Temp Rise / Ambient T°	三相 3 PHASE						单相 1 PHASE						单相 1 PHASE					
相数 PHASE	三相 3 PHASE						单相 1 PHASE						单相 1 PHASE					
星形串联 SERIES STAR	380	400	415	440											Power Factor			
星形并联 PARALLEL STAR	190	200	208	220										0.8	1			
三角形串联 SERIES DELTA	220	230	240	254														
双三角形并联 DOUBLE DELTA								220	230	240	220,230,240							
	KVA	KW	KVA	KW	KVA	KW	KVA	KW	KVA	KW	KVA	KW	KVA	KW	KVA	KW	KVA	KW
SLG224C	42.5	34	42.5	34	42.5	34	30	24	28.5	22.8	28.5	22.8	28.5	22.8	28	22.4	28	28
SLG224D	50	40	50	40	50	40	37.5	30	33.5	26.8	33.5	26.8	33.5	26.8	35	28	35	35
SLG224E	60	48	60	48	60	48	45	36	40	32	40	32	40	32	40	32	40	40
SLG224F	72.5	58	72.5	58	72.5	58	55	44	48.5	38.8	48.5	38.8	48.5	38.8	50	40	50	50
SLG224G	85	68	85	68	85	68	75	60	56.5	45.2	56.5	45.2	56.5	45.2	60	48	60	60

### 60Hz CLASS "H"

RATINGS	绕组形式 311 / 功率因数0.8 Winding 311 / 0.8 Power Factor												绕组形式05 Winding 05					
	持续/125k/40°C Cont./125K/40°C						持续/125k/40°C Cont./125K/40°C						持续/125k/40°C Cont./125K/40°C					
定额/温升/环温T° Duty / Temp Rise / Ambient T°	三相 3 PHASE						单相 1 PHASE						单相 1 PHASE					
相数 PHASE	三相 3 PHASE						单相 1 PHASE						单相 1 PHASE					
星形串联 SERIES STAR	416	440	460	480										Power Factor				
星形并联 PARALLEL STAR	208	220	230	240										0.8	1			
三角形串联 SERIES DELTA	240	254	266	277														
双三角形并联 DOUBLE DELTA								220	230	240	220,230,240							
	KVA	KW	KVA	KW	KVA	KW	KVA	KW	KVA	KW	KVA	KW	KVA	KW	KVA	KW	KVA	KW
SLG224C	50	40	52.5	42	52.5	42	55	44	30.5	24.4	32	25.6	33.5	26.8	37.5	30	37.5	37.5
SLG224D	60	48	62.5	50	62.5	50	65	52	36.5	29.2	38.3	30.6	40	32	44	35	44	44
SLG224E	67.5	54	70	56	72.5	58	75	60	41.3	33	43.1	34.5	45	36	50	40	50	50
SLG224F	83.8	67	87.5	70	87.5	70	93.8	75	50	40	52.5	42	56	45	60	48	60	60
SLG224G	93.8	75	97.5	78	100	80	103.8	83	56.9	45.5	59.4	47.5	62.5	50	70	56	75	75



## SLG224 外形图 External dimension

### 单轴承 SINGLE BEARING

separable side plate  
可拆卸式侧板

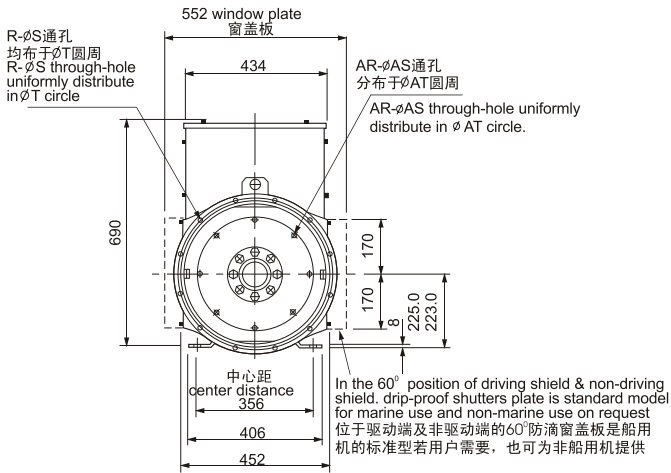
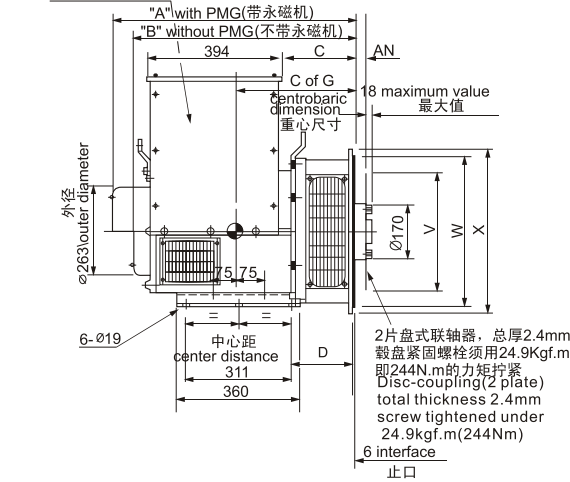

### 双轴承 DOUBLE BEARING

separable side plate  
可拆卸式侧板

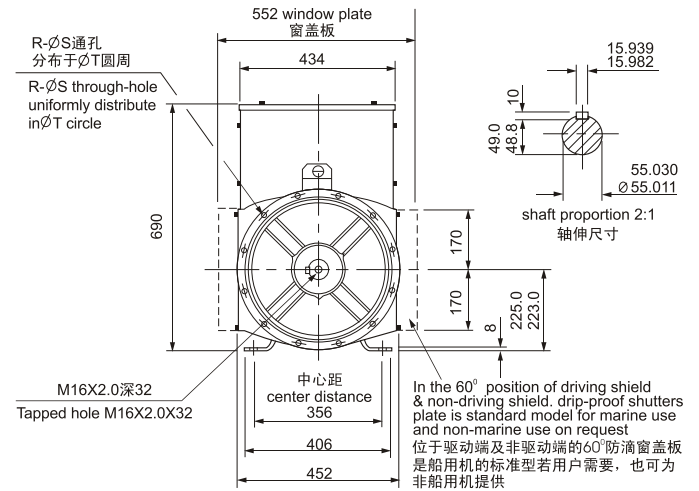
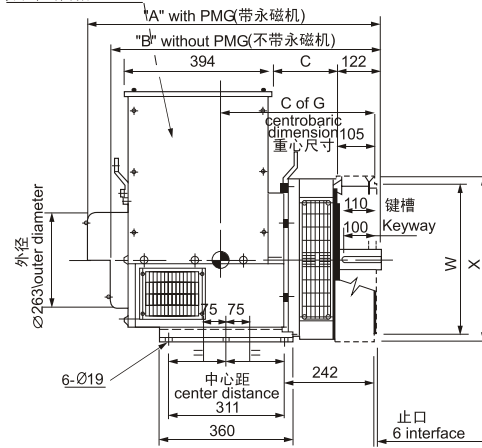

#### DIMENSION 尺寸(mm)

型号Model	A	B	C	C of G	LXWXH(mm)
SLG224C	734	671	233.5	323	820X540X870
SLG224D	734	671	233.5	333	820X540X870
SLG224E	824	761	323.5	348	890X540X870
SLG224F	824	761	323.5	358	890X540X870
SLG224G	869	806	368.5	373	930X540X875
SLG224C	710	647	210	311	820X540X870
SLG224D	710	647	210	321	820X540X870
SLG224E	800	737	300	336	890X540X870
SLG224F	800	737	300	346	890X540X870
SLG224G	845	782	345	361	930X540X875

#### FLANGE 法兰式过渡接套 (mm)

S.A.E.NO.	D	R	S	T	W	X
2	200.5	12	11	466.7	447.6	490
3	177	12	11	428.6	409.5	451
4	200.5	12	11	381.0	361.9	451

#### DISC COUPLING 盘片式联轴器(mm)

S.A.E.NO.	AN	AR	AS	AT	V
8	61.9	6	11	244.4	263.4
10	53.98	8	11	295.3	314.2
11.5	39.68	8	11	333.3	352.3
14	25.40	8	13.5	438.2	466.6

#### DIMENSION 尺寸(mm)

型号Model	A	B	C	C of G	N.W(kg)	G.W(kg)	LXWXH(mm)
SLG224C	792	729	170	368	250	275	820X540X870
SLG224D	792	729	170	378	270	295	820X540X870
SLG224E	882	819	260	393	290	315	930X540X875
SLG224F	882	819	260	403	320	345	930X540X875
SLG224G	927	864	305	418	360	385	930X540X875

#### FLANGE 法兰式过渡接套 (mm)

S.A.E.NO.	R	S	T	W	X
2	12	11	466.7	447.6	495
3	12	11	428.6	409.5	451
4	12	11	381.0	361.9	403
5	8	11	333.3	314.3	356

#### SINGLE BEARING SAE NO SELECTOR 单轴承驱动片和过渡法兰配套表

	SAE8	SAE10	SAE11.5
SAE 2			•
SAE 3		•	•
SAE 4	•	•	