

# NEW ERA SLG

系列三相无刷同步发电机  
SERIES THREE-PHASE BRUSHLESS  
SYNCHRONOUS ALTERNATOR

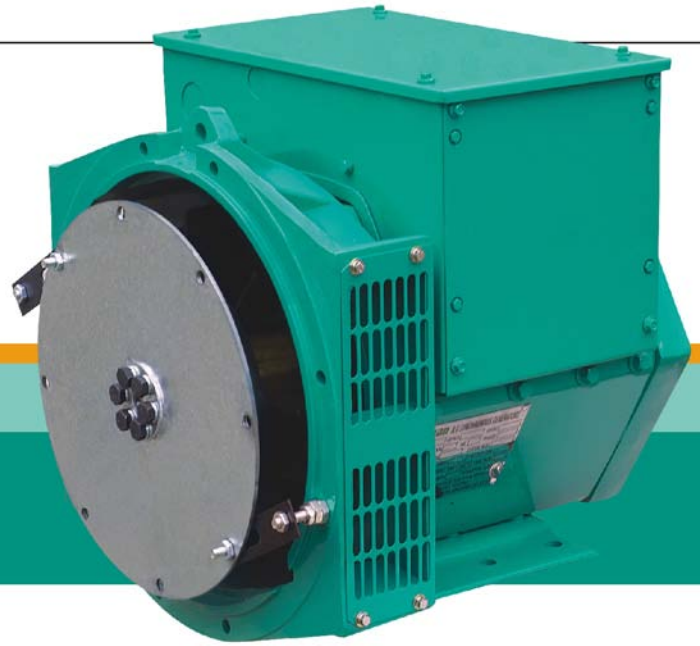

## SLG184 TECHNICAL DATA SHEET

### 50Hz CLASS "H"

RATINGS	绕组形式 311 / 功率因数0.8 Winding 311 / 0.8 Power Factor												绕组形式05 Winding 05					
	持续/125k/40°C Cont./125K/40°C						持续/125k/40°C Cont./125K/40°C						持续/125k/40°C Cont./125K/40°C					
定额/温升/环境温度 Duty / Temp Rise / Ambient T°	三相 3 PHASE						单相 1 PHASE						单相 1 PHASE					
相数 PHASE	三相 3 PHASE						单相 1 PHASE						单相 1 PHASE					
星形串联 SERIES STAR	380	400	415	440											Power Factor			
星形并联 PARALLEL STAR	190	200	208	220										0.8	1			
三角形串联 SERIES DELTA	220	230	240	254														
双三角形并联 DOUBLE DELTA									220	230	240			220,230,240				
	KVA	KW	KVA	KW	KVA	KW	KVA	KW	KVA	KW	KVA	KW	KVA	KW	KVA	KW	KVA	KW
SLG184E	22.5	18	22.5	18	22.5	18	17.5	14	13	10.4	13	10.4	13	10.4	15	12	16.6	16.6
SLG184F	27.5	22	27.5	22	27.5	22	22.5	18	16	12.8	16	12.8	16	12.8	18.5	14.8	20	20
SLG184G	31.3	25	31.3	25	31.3	25	27.5	22	18.1	14.5	18.1	14.5	18.1	14.5	21	16.8	22.8	22.8
SLG184H	37.5	30	37.5	30	37.5	30	32.5	26	21.7	17.4	21.7	17.4	21.7	17.4	25	20	27	27
SLG184J	40	32	40	32	40	32	35	28	23.2	18.6	24.7	19.8	23.2	18.6	28	22.4	30	30

### 60Hz CLASS "H"

RATINGS	绕组形式 311 / 功率因数0.8 Winding 311 / 0.8 Power Factor												绕组形式05 Winding 05					
	持续/125k/40°C Cont./125K/40°C						持续/125k/40°C Cont./125K/40°C						持续/125k/40°C Cont./125K/40°C					
定额/温升/环境温度 Duty / Temp Rise / Ambient T°	三相 3 PHASE						单相 1 PHASE						单相 1 PHASE					
相数 PHASE	三相 3 PHASE						单相 1 PHASE						单相 1 PHASE					
星形串联 SERIES STAR	416	440	460	480											Power Factor			
星形并联 PARALLEL STAR	208	220	230	240										0.8	1			
三角形串联 SERIES DELTA	240	254	266	277														
双三角形并联 DOUBLE DELTA									220	230	240			220,230,240				
	KVA	KW	KVA	KW	KVA	KW	KVA	KW	KVA	KW	KVA	KW	KVA	KW	KVA	KW	KVA	KW
SLG184E	27.5	22	28.8	23	28.8	23	30	24	14.6	11.7	15.3	12.2	16	12.8	18.4	14.7	21	21
SLG184F	32.5	26	34.4	27.5	34.4	27.5	35	28	17.2	13.8	18	14.4	18.8	15	21.9	17.5	25.6	25.6
SLG184G	35	28	37.5	30	37.5	30	37.5	30	18.7	15	19.5	15.6	20.3	16.2	25	20	30	30
SLG184H	44.3	35.4	46.9	37.5	46.9	37.5	46.9	37.5	23.6	18.9	24.6	19.7	25.7	20.6	31.3	25	35	35
SLG184J	47.3	37.8	50	40	50	40	50	40	25	20	26.3	21	27.4	21.9	35	28	40	40

# SLG184 外形图 External dimension

## 单轴承 SINGLE BEARING

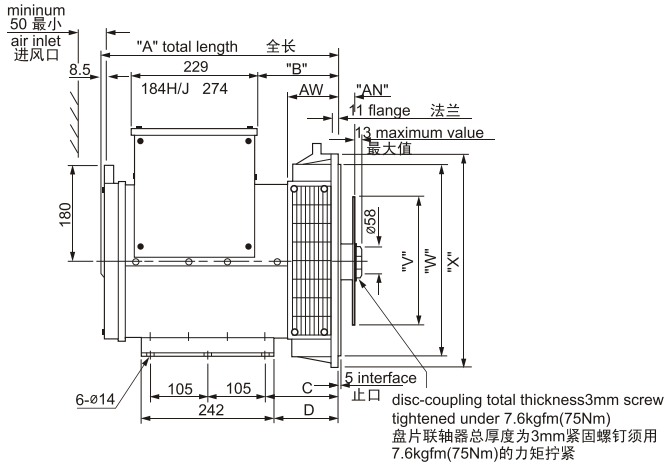

## 双轴承 DOUBLE BEARING

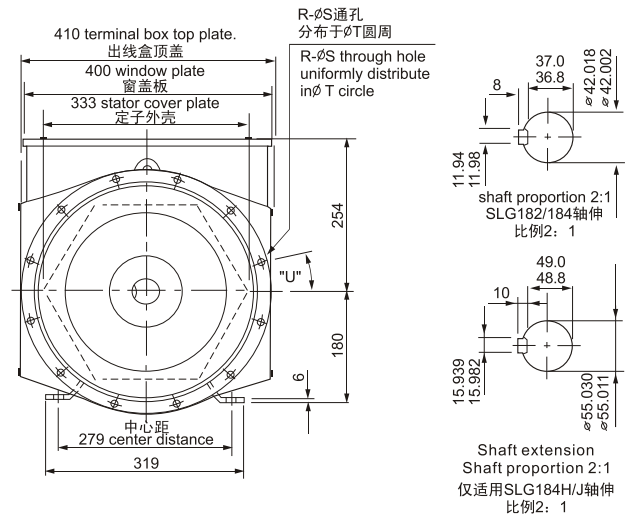
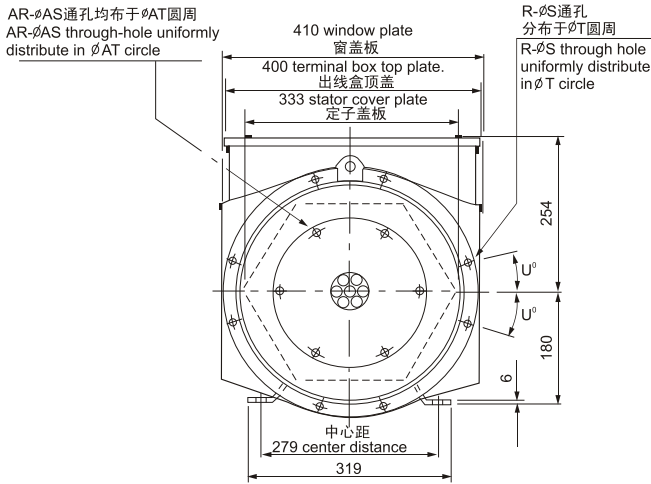
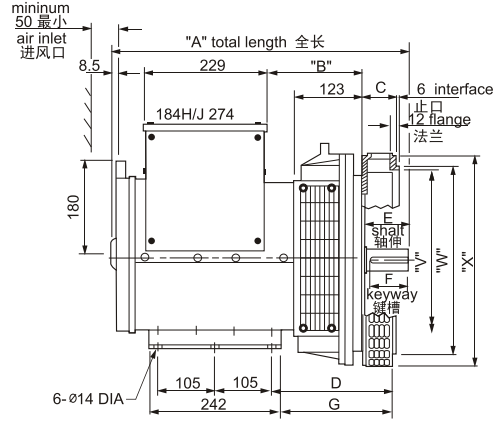

### DIMENSION 尺寸(mm)

型号 Model	A				B				N.W/G.W (kg) (kg)		LXWXH (mm)
	SAE2	SAE3	SAE4	SAE5	SAE2	SAE3	SAE4	SAE5			
SLG184E	471	443.5	431.5	443.5	186	159	147	159	120	133	565X485X620
SLG184F	561	533.5	521.5	553.5	276	249	237	269	150	156	675X510X620
SLG184G	561	533.5	521.5	553.5	276	249	237	269	156	172	675X510X620
SLG184H	620.5	593.5	581.5	613.5	291	264	252	284	216	226	740X510X620
SLG184J	620.5	593.5	581.5	613.5	291	264	252	284	226	236	740X510X620

### DIMENSION 尺寸(mm)

型号 Model	A	B	C	D	E	F	G	N.W (kg)	G.W (kg)	LXWXH (mm)
	SLG184E	551.5	177	65	228	82	77	212	131	141
SLG184F	641.5	267	65	228	82	77	212	154	164	740X510X620
SLG184G	641.5	267	65	228	82	77	212	170	180	740X510X620
SLG184H	734.5	282	105	268	110	100	252	220	230	820X510X620
SLG184J	734.5	282	105	268	110	100	252	230	240	820X510X620

### FLANGE 法兰式过渡套件 (mm)

S.A.E.NO.	AW	R	S	T	U°	W	X	C	D
2	132.3	12	11	466.7	15	447.6	489	172	156
3	105	8**	11	428.6	15	409.5	451	145	129
4	93	8	11	381.0	15	361.9	402	133	117
5	125(105)***	8	11	333.3	22.5	314.3	356	165(145)***	149(129)***
6*	136.7	8	11	285.8	22.5	266.7	308	176.7	160.7

### FLANGE 法兰式过渡套件 (mm)

S.A.E.NO.	R	S	T	U°	V	W	X
1	12	12.7	530.2	15	500	511.17	553
2	12	11	466.7	15	432	447.6	495
3	12	11	428.6	15	396	409.5	451
4	12	11	381.0	15	352	361.9	403
5	8	11	333.3	22.5	301	314.3	356

注:\*SAE6需另加一厚31.7mm的过渡板,故"A"尺寸也相应增加31.7mm

\*\*SAE3的8个孔分布于12等分的圆周上

\*\*\*SLG184E的AW尺寸为105, C尺寸为145, D尺寸为129

NOTE:\* "A" dimension should extend 31.7mm corresponding to an additional spacer plate added on SAE6

\*\* 8 holes of SAE3 uniformly distribute on the circle spaced as 12.

\*\*\* The AW dimension of 184E should be 105,C dimension is 145,D dimension is 129.

注:SAE5不适用于SLG 184H/J

### DISC COUPLING 盘片式联轴器 (mm)

S.A.E.NO.	AN	AR	AS	AT	V
6.5 Δ	30.16	6	8.7	200.0	215.8
7.5 Δ	30.16	8	8.7	222.2	241.2
8	61.9	6	11	244.5	263.4
10	53.98	8	11	295.3	314.2
11.5	39.68	8	11	333.4	352.3
14 Δ	25.4	8	13.5	438.2	466.5

注: SAE14仅适用于SLG184H/J铁心;SAE6.5,7.5不适用SLG184H/J铁心

NOTE: Δ SAE14 is applicable for SLG184H/J iron core;

SAE6.5&7.5 are not applicable for SLG184H/J iron core.

### SINGLE BEARING SAE NO SELECTOR 单轴承驱动片和过渡法兰配套表

	SAE 6.5	SAE 7.5	SAE 8	SAE 10	SAE 11.5
SAE 3	•	•		•	•
SAE 4		•	•		
SAE 5	•	•			
SAE 6	•				